



3" Side Bar

Part No. A0064S /B



Fits: 2020-Current FORD EXPLORER



60-180 min

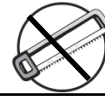

Cutting Not Required



Drilling Not Required



REMOVE CONTENTS FROM BOX. VERIFY ALL PARTS ARE PRESENT.



support@trailfx.com



READ INSTRUCTIONS CAREFULLY BEFORE STARTING INSTALLATION.



1 866 638 4870

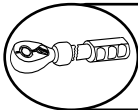

DO NOT OVER TORQUE. STANDARD OPERATING LOAD FOR TIGHTEN BODY MOUNT NUTS & BOLTS VARIES FROM 45 TO 65 FOOT POUND.



POLISHED STAINLESS STEEL – LIMITED LIFETIME
POWDER COATED BLACK – 3 YEARS

PARTS LIST:

Qty	Part Description	Qty	Part Description
1	Driver/Left Sidebar	6	10mm Clip Nuts
1	Passenger/Right Sidebar	12	8-1.25mm x 25mm Hex Nuts
3	Driver/Left Mounting Brackets	12	8-1.25mm x 25mm Combo Bolts
3	Passenger/Right Mounting Brackets	24	8mm x 24mm OD x 2mm Flat Washers
6	10-1.5mm x 30mm Hex Bolts	12	8mm Lock Washers
6	10mm Lock Washers	12	8mm Hex Nuts
6	10mm x 30mm OD x 2.5mm Flat Washers		

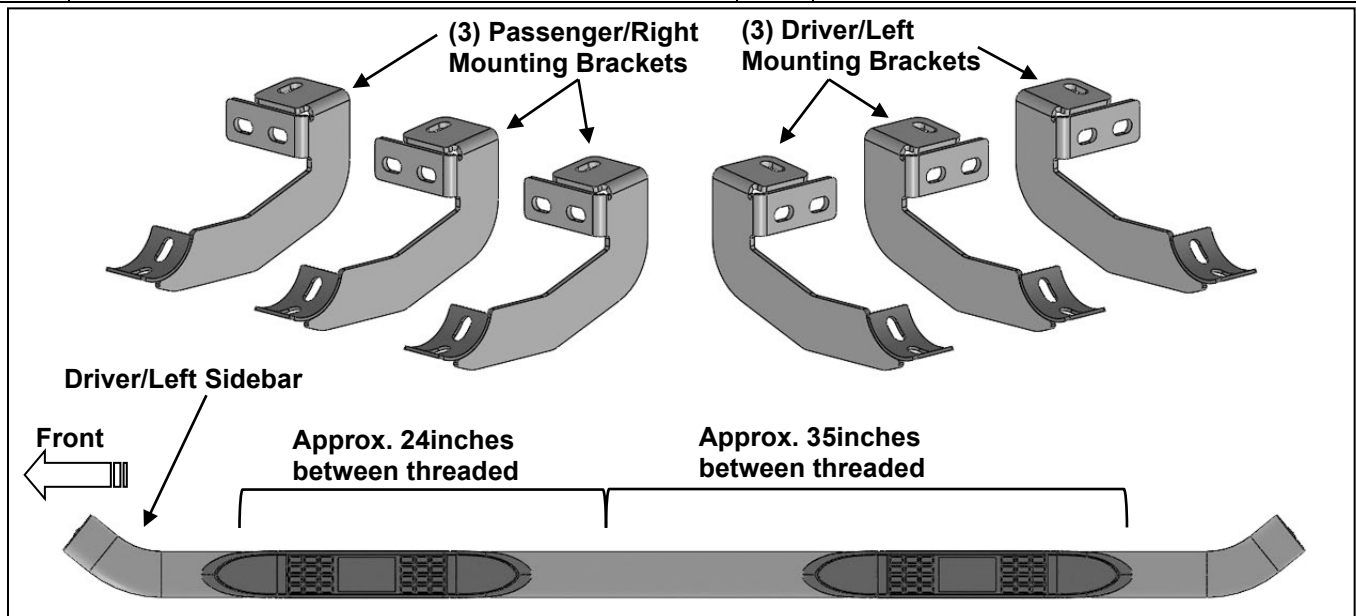

PROCEDURE:

1. REMOVE CONTENTS FROM BOX. VERIFY ALL PARTS ARE PRESENT. READ INSTRUCTIONS CAREFULLY BEFORE STARTING INSTALLATION.
2. Starting from under the front Driver/Left side, temporarily remove the plastic side panel. Move to the floor panel, locate the square holes and (2) round holes in the pinch weld, (Figure 1). Select (1) 10mm Clip Nut. Attach the Clip Nut into the square hole in the floor panel, (Figure 2).
3. Select (1) Driver/Left Mounting Bracket. Attach the Bracket to the 10mm Clip Nut with (1) 10mm Hex Bolt, (1) 10mm Lock Washer and (1) 10mm Flat Washer, (Figures 3 & 5). Do not tighten hardware.
4. Attach the Mounting Bracket to the pinch weld with (2) 8mm Hex Bolts, (4) 8mm Flat Washers, (2) 8mm Lock Washers and (2) 8mm Hex Bolts, (Figure 4). Do not tighten hardware.
5. Move along the body to the center mounting location, (Figure 6). Repeat Steps 2—4 to attach the Mounting Bracket to the center location, (Figure 7). Do not tighten hardware.

6. Move to the rear mounting location. Repeat **Steps 2—4** to attach the remaining (1) Driver/Left Mounting Bracket, (**Figures 8 & 9**). Do not tighten hardware.
7. Reattach the plastic side panel.
8. Unwrap the Driver/Left Sidebar. Carefully place Sidebar on the brackets. **IMPORTANT:** Do not slide or rotate Sidebar on cradles, or damage to the finish may result. Attach Sidebar to the Mounting Brackets with (6) 8mm Combo Bolts. Do not tighten hardware at this time, (**Figures 10—13**).
9. Level and adjust Sidebar and tighten all hardware.
10. Repeat **Steps 2—8** to attach the Passenger/Right Sidebar.
11. Do periodic inspections to the installation to make sure that all hardware is secure and tight.

To protect your investment, Do not use any type of polish or wax that may contain abrasives that could damage the finish. Mild soap may be used to clean the Sidebar.

Driver/Left side Installation Pictured



(Fig 1) Driver/Left front mounting location

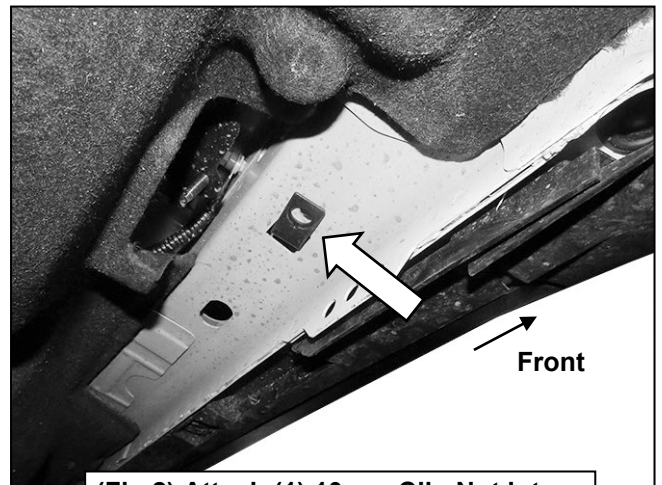

(Fig 2) Attach (1) 10mm Clip Nut into the Driver/Left front mounting location

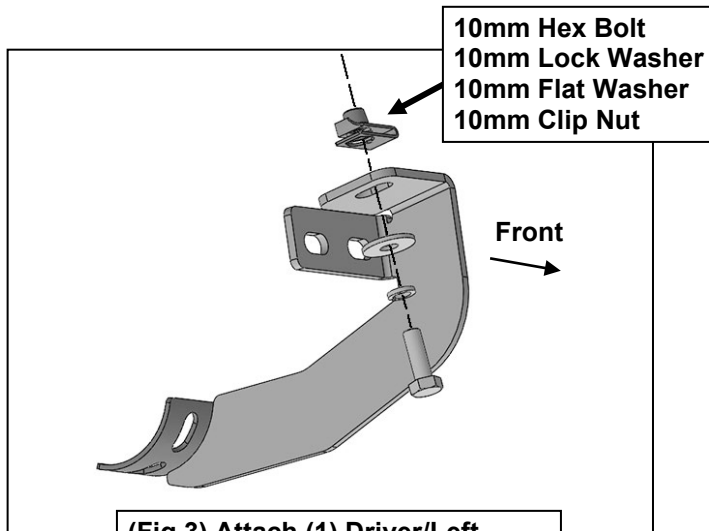

(Fig 3) Attach (1) Driver/Left Mounting Bracket to the Clip Nut

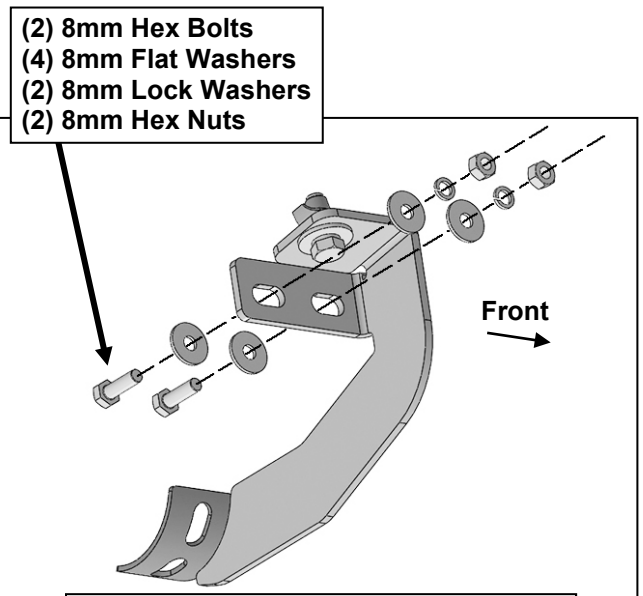

(Fig 4) Attach the Driver/Left Mounting Bracket to the pinch weld

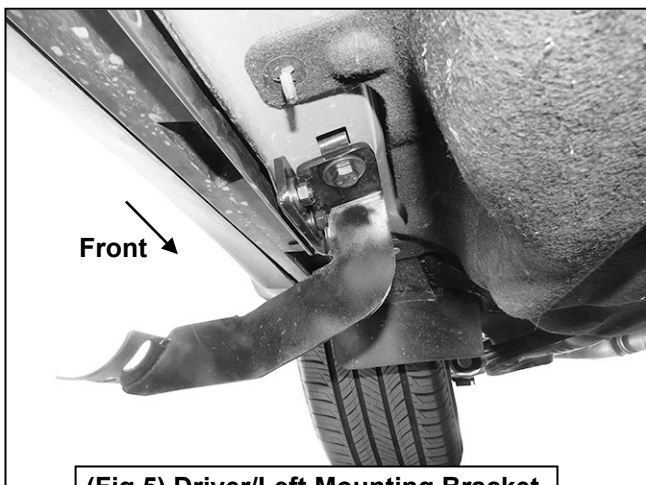

(Fig 5) Driver/Left Mounting Bracket attached to the front location

Driver/Left side Installation Pictured

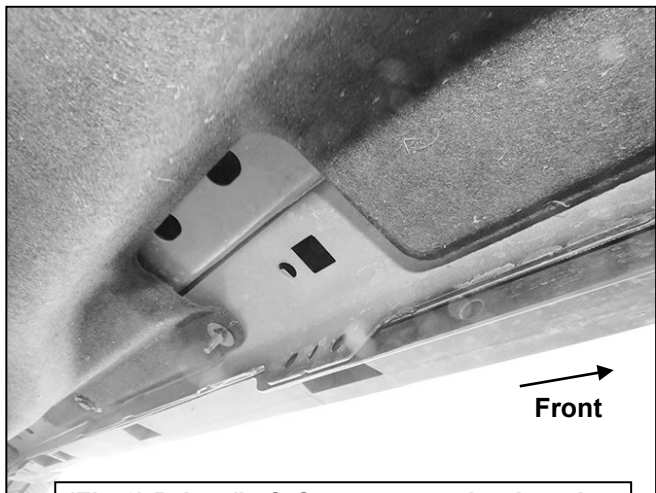

(Fig 6) Driver/Left Center mounting location

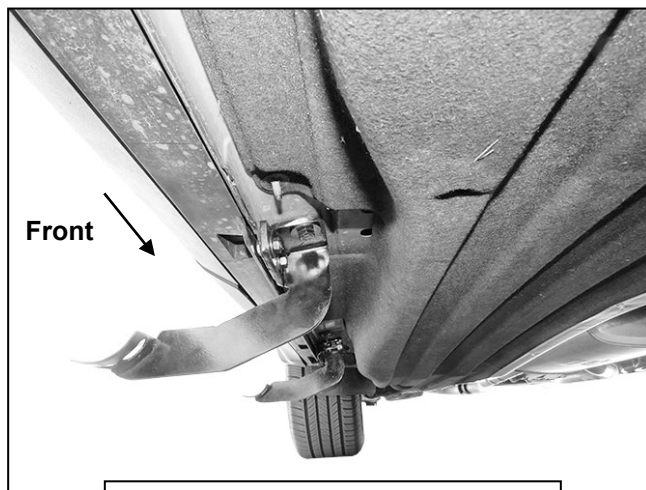

(Fig 7) Mounting Bracket attached to the Driver/Left center location

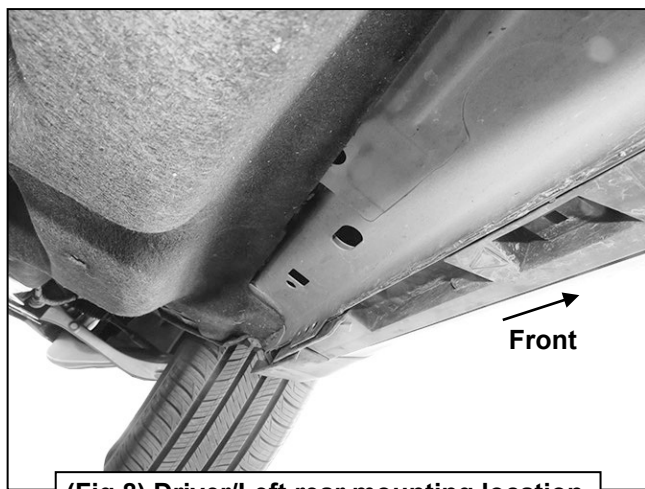

(Fig 8) Driver/Left rear mounting location

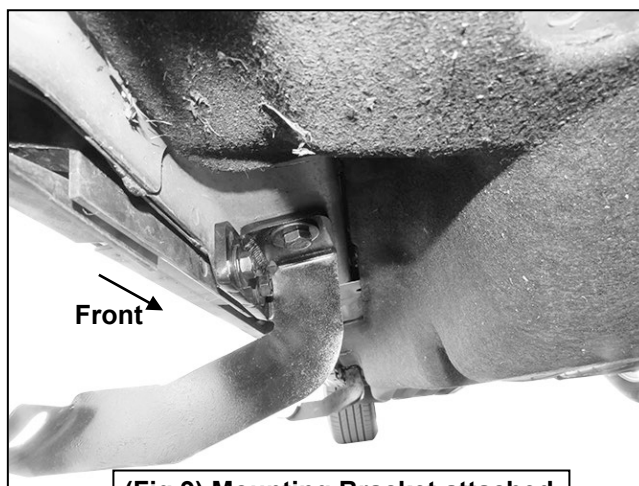

(Fig 9) Mounting Bracket attached to the Driver/Left rear location

Driver/Left side Installation Pictured

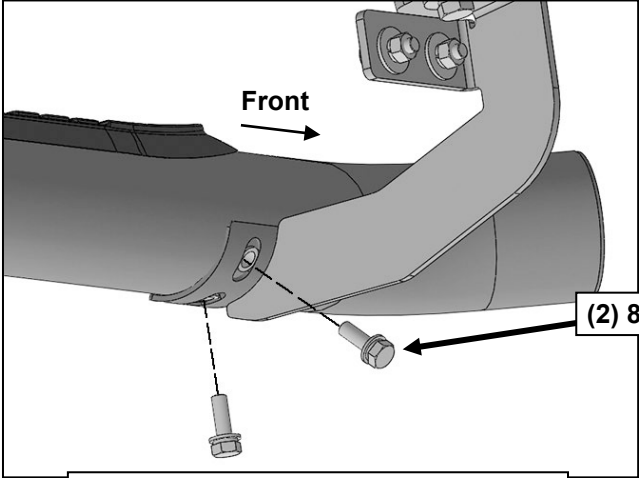

(Fig 10) Attach the Driver/Left Sidebar to the front Mounting Bracket

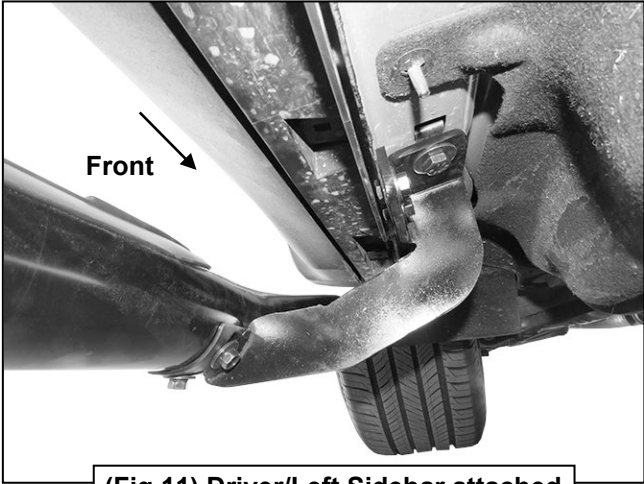

(Fig 11) Driver/Left Sidebar attached to the front Mounting Bracket

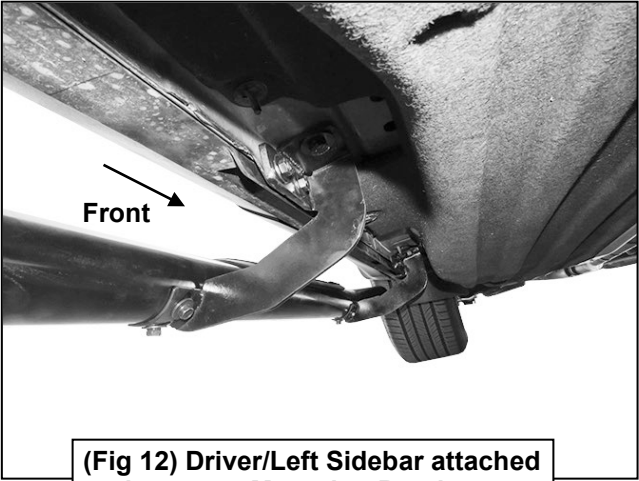

(Fig 12) Driver/Left Sidebar attached to the center Mounting Bracket

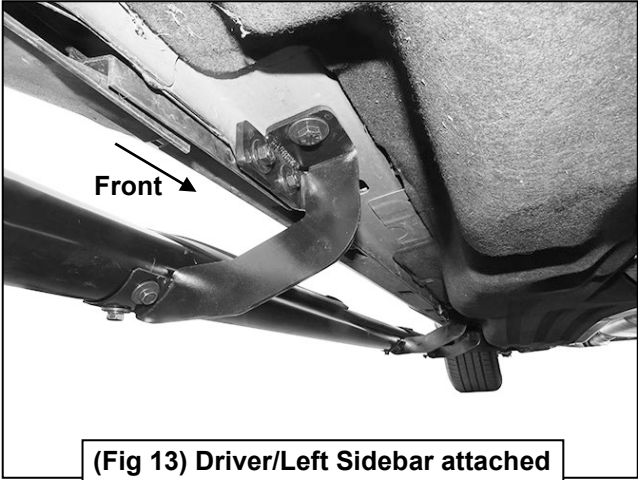

(Fig 13) Driver/Left Sidebar attached to the rear Mounting Bracket

No.	Parts Identification
1	Passenger / Right 'Rear' Bracket marked "PR"
2	Driver / Left 'Rear' Bracket marked "DR"
3	Passenger / Right 'Center' Bracket marked "PC"
4	Driver / Left 'Center' Bracket marked "DC"
5	Passenger / Right 'Front' Bracket marked "PF"
6	Driver / Left 'Front' Bracket marked "DF"

Note:

- This guide is to identify the parts and not a reference for part count.
- For part count, refer Parts List.
- Product / Bracket image is representative and actual design may vary.

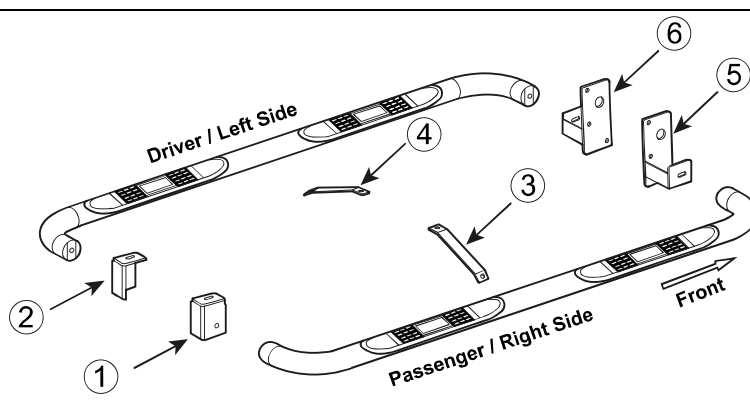
**PRODUCT CARE**

- Periodically check the product to ensure all fasteners are tight and components are intact.
- Regular waxing is recommended to protect the finish of the product.
- **Use ONLY Non-Abrasive automotive wax.** Use of any soap, polish or wax that contains an abrasive is detrimental and can scratch the finish leading to corrosion.
- Aluminum polish may be used to polish small scratches and scuffs for **Stainless Steel finish.**
- Mild soap may be used to clean the product for both **Stainless Steel and Black finish.**

FAQ's**1. Hardware's are not of correct size.**

In GMC / Chevrolet truck model 2006 & up, customer needs to reuse the factory body bolts to install the bracket. If your vehicle is not GMC / Chevrolet 2006 & up, ensure that holes are not partially covered with any plastic grommet or rust? If it is, remove the plastic grommet & rust from the thread holes & re-try the installation.

2. Mounting Bracket are not getting Installed properly.

In some cases Illustration images shown in Installation manual may not be the exactly same as per actual vehicle images ,also if Driver / Passenger side mounting brackets are very identical in the design, suggest referring Parts Identification guide to avoid fitment issue.

3. Products are thumping / rattling after installation.

Ensure that all required mounting brackets / hardware's are installed & tighten correctly. Suggest using white lithium / regular grease between the metal to metal contact surfaces.

4. Side Bar is not aligning with vehicle / Step Pads are not aligning with vehicle doors.

Side bar may be interchanged or mounting brackets are not installed at the correct position in the vehicle. Refer Parts identification guide.

5. Missing / Excess Hardware.

Recheck hardware count as per the part list.

6. Product not installing properly.

Ensure make model year, cab length and bed size of your vehicle is listed in the application. All installation steps are followed correctly.

Check out these other TrailFX Products!!

www.TrailFX.com



BULL BAR



GRILLE GUARDS



BED RAILS



RUNNING BOARDS

Keystone Automotive Operations Inc. (KAO) warrants this product to be free of defects in material and workmanship at the time of purchase by the original retail consumer. KAO disclaims any other warranties, express or implied, including the warranty of fitness for a particular purpose or an intended use. If the product is found to be defective, KAO may replace or repair the product at our option, when the product is returned prepaid, with proof of purchase. Alteration to, improper installation, or misuse of this product voids the warranty. KAO's liability is limited to repair or replacement of products found to be defective, and specifically excludes liability for any incidental or consequential loss or damage.